

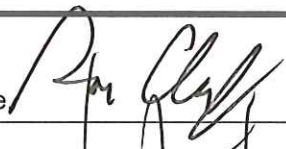

## **Field Service Spares Enhancement Procedure – Interface Harness and Spindle Wrap Kit, Coastal**

Approval:

Approving Authority	Signature	Date
Doc Control:	Ron Chaffee / Signature on file 	5-30-12
Assistant Service Manager, Global	John VanderJagt / Signature on file. 	5/30/12
Author:	Shawn Fetherkile / Signature on file. 	5/20/12

### Revision History

Rev.	ECO	Description of Change	Date
A	9412	Initial release	05-04-2012

# ***Field Service Procedure – Enhancement Interface Harness and Spindle Wrap Kit, Coastal***

---

## **1. Brief Summary:**

Troubleshooting document for diagnosing a fault with and replacing the interface harness and spindle wrap on the Coastal series antennas.

## **2. Checklist:**

- Verify the Pedestal is Powered
- Verify ADE/BDE Communications
- Verify the Harness Connections

## **3. Theory of Operation:**

The interface harness of the Coastal series antenna is used to pass the RS-422 communications from the digital antenna control panel (DACP), via the control cable to the pedestal control unit (PCU) as well as the 12VDC to power the system. Under normal operation the interface harness will coil and uncoil to allow the pedestal to rotate while the system drives in azimuth to counteract changes in the vessels heading. The Coastal series antennas have a total of 680 degrees of rotation before making contact with their mechanical end stops, at which point the system will unwrap, rotating 360 degrees back into its range of motion.

## **4. Verify Power to the Antenna:**

The Coastal series antennas are powered by 12VDC which is fed into the control panel and in turn passed to the antennas pedestal control unit (PCU) via the control cable and interface harness. If the antenna is not operational verify the 12VDC at the power source and that the fuse in the control panel is intact, if not troubleshoot the source.

The 12VDC should then be measured exiting the control cable in the above decks on the round socket connector which is terminated against the interface bracket in the radome base on pins 9 (+12V) and 5 (ground). If the 12VDC is present then measure it on the interface harnesses 15-pin D-sub connector entering the PCU on pins 15 (+12V) and 14 (ground). If the voltage was measured entering the interface harness at the socket connector in the radome, but can't be measured in the 15-pin connector entering the PCU the interface harness is defective and needs to be replaced.

If the 12VDC is present on the 15-pin connector entering the PCU but the system isn't powered this is an indication that the PCU is defective.

Page 1 of 9	<b>Sea Tel</b> COBHAM	Document No 137273 Rev A
-------------	--------------------------	-----------------------------

# Field Service Procedure – Enhancement Interface Harness and Spindle Wrap Kit, Coastal

## 5. Verify Communications:

If there is a communications fault with the system the control panel won't be able to display feedback from the PCU and therefore will only display the DACP software version installed on it. If this is the case verify that the pedestal is powered (as per the above step). Check the harness for good continuity from point-to-point and that there are no shorts from wire-to-wire or from wire-to-ground that are not supposed to be there as per the below diagram.

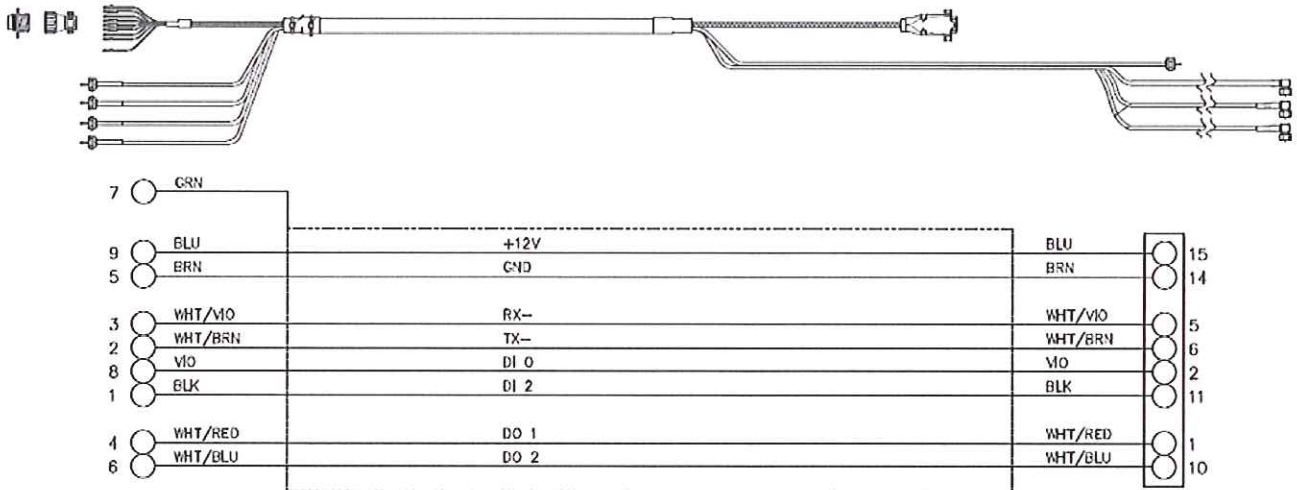



# Field Service Procedure – Enhancement Interface Harness and Spindle Wrap Kit, Coastal



## 6. Replacing the Coastal Series Interface Harness:

### 6.1. Tools:





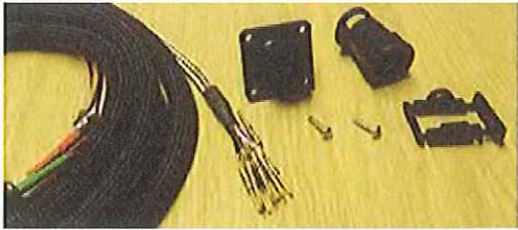

- 9/16" Wrench/Spanner
- 7/16" Wrench/ Spanner
- 1 1/2" Wrench/ Spanner
- #1 Phillips Screwdriver
- 1/4" Wrench/Spanner
- Snips/Cutters
- Force Gauge
- Loctite 242

### 6.2. Procedure:

Procedure for replacing the Interface harness, Sea Tel kit part number: 136228-2 for the C18, C20 and C24 antennas or 132668-1 for the C30 antenna. (Harness assembly part number: 124651-2 for the C18, C20 and C24 antennas or 124651-1 for the C30 antenna).







<p><b>*Caution:</b> Power down the pedestal before following this procedure.</p> <p><b>*Note:</b> The harness comes without the socket connector installed. DO NOT ATTACH THE CONNECTOR AT THIS TIME.</p>	
<p>1. Remove the radome top using a 7/16" wrench or socket, then undo the 4 Nuts securing the pedestal to the radome using a 9/16" wrench. Remove the pedestal assembly from the radome base.</p>	
<p>2. Disconnect the four coax cables from the mounting bracket using a 7/16" wrench.</p>	

## Field Service Procedure – Enhancement Interface Harness and Spindle Wrap Kit, Coastal

<p>3. Now disconnect the interface harness socket connector using a #1 Phillips screwdriver and a 1/4" wrench. Save the hardware for future use.</p> <p><i>*Note:</i> The upper part of the bracket is connected by the hardware for the socket connector.</p>	
<p>4. Now using a #1 Phillips screwdriver remove the retaining screw and P-clip securing the harness to the mounting bracket. Save the hardware for future use.</p>	
<p>5. Snip the cable tie securing the interface harness to the azimuth spindle.</p>	
<p>6. Snip the cable tie securing the interface harness to the elevation motor cable.</p>	
<p>7. Remove the retaining screw and P-clip securing the interface harness to the yoke. Save the hardware for future use.</p>	
<p>8. Remove the cable wrap from the pol harness and coax cables &amp; the lower section of cable wrap.</p>	



## Field Service Procedure – Enhancement Interface Harness and Spindle Wrap Kit, Coastal

<p>9. Snip the cable tie retaining the coax cables to the PCU.</p>	
<p>10. Disconnect the red (RF-OUT) coax cable from the PCU using a 7/16" wrench.</p> <p><b>*Note:</b> The yellow (RF-IN) coax will have to be removed to allow access to the red coax.</p>	
<p>11. Using a 7/16" wrench remove the coax cables from the LNB, except the yellow cable which connects to the PCU.</p> <p><b>*Note:</b> You may want to photograph the orientation the cables are connected in for future reference.</p>	
<p>12. Snip the cable ties securing the coax to the LNB.</p>	
<p>13. Using a 2mm flat blade screwdriver remove the interface harness D-sub connector from the PCU.</p>	
<p>14. The interface harness can now be removed from pedestal, as it is defective it can be cut for ease of removal.</p>	

## Field Service Procedure – Enhancement Interface Harness and Spindle Wrap Kit, Coastal

15. Take note of the resistance of the antenna by spinning it from AZ stop to AZ stop checking for any binding. After installing the spindle wrap you will verify the resistance is the same to make sure the antenna moves freely without any binding.

16. Using a 1 1/2" Wrench remove the 1-14 Nut.

**\*Note:** Because of Loctite on the threads you may want to apply heat from a heat gun to remove the nut easily. Be careful not to overheat the bearings.

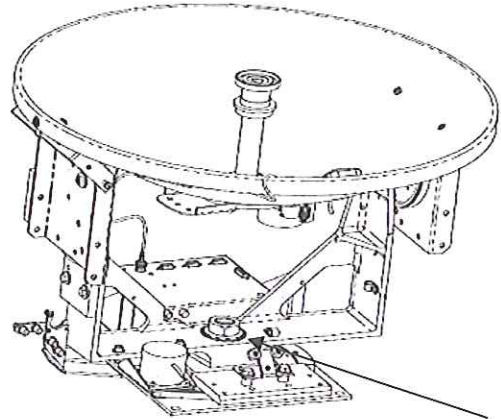

17. Dry fit the spindle wrap all the way down, then remove the spindle wrap to ensure it runs free before assembling.

- 128720 for C-20, C-24, & C-30

- 128720-1 for C-18

18. Apply Loctite 2760 to the inner threads of the spindle wrap. Mount onto spindle, and then tighten by hand until all play is eliminated. Apply an extra 8<sup>th</sup> of a turn to secure.

19. Verify the yoke movement ensuring the antenna moves freely without and binding as previously done in step 15.

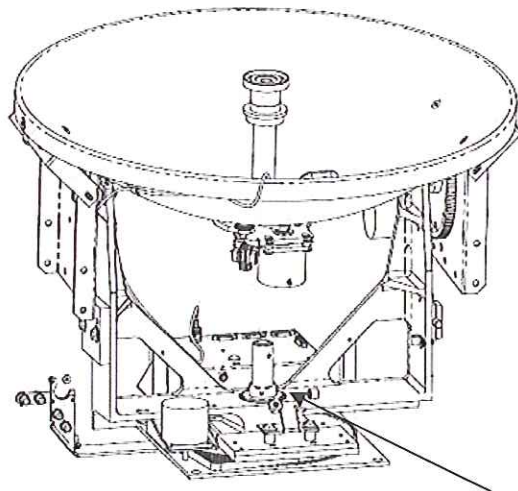





20. Feed the bare pin end of the replacement harness through the top azimuth spindle and feed it out the base plate.



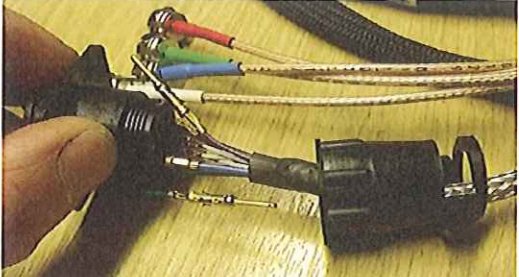



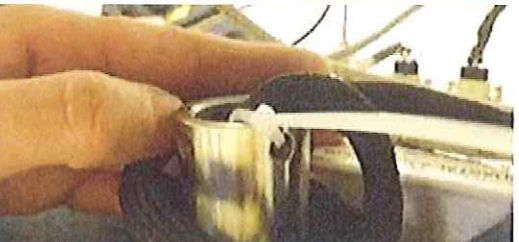

## **Field Service Procedure – Enhancement Interface Harness and Spindle Wrap Kit, Coastal**

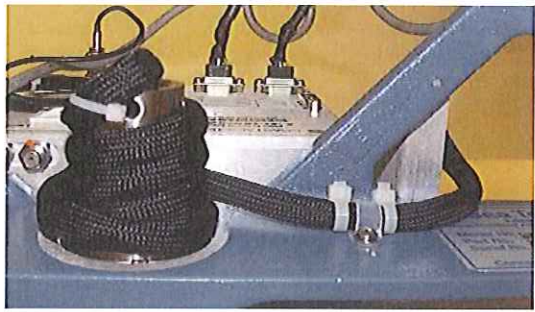

<p>21. Slide the lower section of the connector over the cable and insert the pins into the socket connector in the following configuration:</p> <table style="width: 100%; border: none;"> <tr> <td style="width: 33%;">1 - Black</td> <td style="width: 33%;">2 - White/Brown</td> <td style="width: 33%;">3 - White/Violet</td> </tr> <tr> <td>4 - White/Red</td> <td>5 - Brown</td> <td>6 - White/Blue</td> </tr> <tr> <td>7 - Green</td> <td>8 - Violet</td> <td>9 - Blue</td> </tr> </table>	1 - Black	2 - White/Brown	3 - White/Violet	4 - White/Red	5 - Brown	6 - White/Blue	7 - Green	8 - Violet	9 - Blue	
1 - Black	2 - White/Brown	3 - White/Violet								
4 - White/Red	5 - Brown	6 - White/Blue								
7 - Green	8 - Violet	9 - Blue								
<p>22. Screw the lower section of the harness onto the socket connector and attach the retainer using a #1 Phillips screwdriver.</p>										
<p>23. Install the replacement interface harness socket connector and upper part of the mounting bracket, using a #1 Phillips screwdriver and a 1/4" wrench.</p>										
<p>24. Reconnect the coax cables to the mounting bracket using a 7/16" wrench.</p>										
<p>25. Secure the heat-shrunk section of the interface harness to the mounting bracket, applying Loctite 242 to the screw. Ensure the harness and coax cables aren't pulled too tightly before fully tightening.</p>										
<p>26. Pull any excess of the harness through the top of the azimuth spindle (ensuring it's not too tight or chafing) and secure to the top of the spindle using a cable tie.</p>										

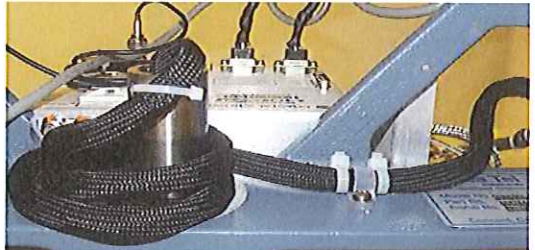

## Field Service Procedure – Enhancement Interface Harness and Spindle Wrap Kit, Coastal

<p>27. Rotate the pedestal clockwise in azimuth until it comes into contact with its end stop and coil the harness around the spindle several times, ensuring to keep the harness running freely (I.e. not twisting the cables inside the sheathing).</p> <p>28. Apply Loctite 242 to the thread of the retaining screw and install the P-clip to secure the harness in place. Install a cable tie either side of the P-clip to prevent the harness from moving.</p>	
<p>29. Ensure the cable isn't too tight around the spindle, or between the spindle and P-clip. If so remove the cable ties and loosen the P-clip screw to add additional slack then install replacement cable ties.</p>	
<p>30. Rotate the azimuth axis of the pedestal counter-clockwise until it reaches its end stop and verify the harness uncoils consistently without completely unraveling (as shown on the right). If the harness unravels itself additional coil(s) need to be wrapped around the azimuth spindle.</p>	
<p>31. Feed the excess harness and connectors through the yoke of the system and connect the interface harness D-sub connector to the PCU using a 2mm flat blade screwdriver.</p>	
<p>32. Reconnect the red coax from the interface harness to the RF-OUT port &amp; the yellow coax from the LNB to the RF-IN port of the PCU using a 7/16" wrench.</p>	

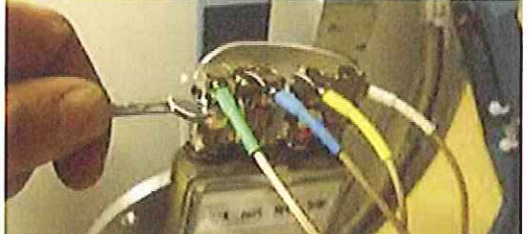
## Field Service Procedure – Enhancement Interface Harness and Spindle Wrap Kit, Coastal

<p>33. Secure the RF-IN and RF-OUT coax cables, azimuth motor cable and GPS antenna cable to the retaining clip on the PCU using a cable tie. Ensure the bend radius of the coax cables is not too sharp.</p>	
<p>34. Connect the coax cables to LNB in the original order from step 11 and tighten using a 7/16" wrench.</p>	
<p>35. Secure the coax cables to the LNB using cable ties.</p>	
<p>36. Install the longer section of cable wrap to the upper part of the LNB's coax cables and pol harness (as shown on the right).</p>	
<p>37. Now secure the lower section of the pol harness to the coax cables from the PCU using the shorter piece of cable wrap.</p>	