



**Field Service Spares Replacement Procedure – Pol Pot Kit, VSAT,
XX97, XX97A & XX97B**

Approval:

Approving Authority	Signature	Date
Doc Control:	Ron Chaffee / Signature on file. 	11-1-11
Assistant Service Manager, Global	John Vanderlagt / Signature on file. 	11-1
Author:	Stuart Broadfield / Signature on file. 	11-01-11

Revision History

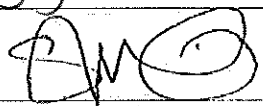
Rev.	ECO	Description of Change	Date
X1	8873	Initial release	08-18-2011
A	9059	Clerical revisions	10-30-2011

Page 1 of 1	Sea Tel <small>COBHAM</small>	Document No 135328 Rev A
-------------	---	-----------------------------

Copyright © Sea Tel, Inc 2011 - The information contained in this document is proprietary to Sea Tel, Inc.. This document may not be reproduced or distributed in any form without prior written consent of Sea Tel, Inc.

Field Service Procedure – Pol Pot Kit, VSAT, XX97, XX97A & XX97B

1. Brief Summary:

Troubleshooting document for diagnosing a fault with and replacing the pol pot on the XX97, XX97A and XX97B series VSAT antennas.

2. Checklist:

- Verify Range of Motion
- Verify Pot Feedback
- Measure Resistance

3. Theory of Operation:

A polang potentiometer is used as a reference for the position of the feed assembly for linear polarization. Throughout its range the resistance of the pot increases from 0 ohms – 5 ohms (or decreases from 5 ohms – 0 ohms) and the PCU converts the voltage output from the pot into the numerical value displayed on the DAC. A failure with the pot causing it to output an incorrect resistance will result in the feed assembly not being aligned correctly causing bad cross pol isolation.

An indication that there is a fault with the feed alignment of the system is the target light will be permanently illuminated on the DAC and the antenna won't target correctly, sitting 8 degrees above (or 8 degrees below at high elevation look angles) the satellites elevation look angle. As part of the antennas targeting procedure the system will target 8 degrees above (or 8 degrees below at high elevation look angles) the satellite, calculate the auto threshold setting based on the noise floor level and then align the feed for the correct reception position based on the vessels GPS position and the lookup table in the DAC.

If the system is unable to drive the pol motor so the correct feedback is received from the pot or the pot has failed and won't give the correct feedback the antenna can't complete the target process and the antenna will stay in this position. Setting the pol type to "000g" will make the antenna target by removing the auto pol function from the targeting process; however the miss alignment of the feed will cause bad cross pol isolation.

Page 1 of 8	Sea Tel COBHAM	Document No 135328 Rev A
-------------	--------------------------	-----------------------------

4. Verify the Range of Motion:

Firstly verify the settings in the DAC are correct, the pol scale should be set to “0090” to give the feed 180 degrees of motion and the default pol offset setting is “0030”, however this may have been modified slightly to “trim” the pol angle.

Set the pol type setting in the setup menu of the DAC to “0009” to set the mode of the pol assembly to manual. Now enter the pol window (after the relative window in the “antenna” screen of the DAC) and hold the down arrow to drive the feed assembly into its end stop. At the lower end of the range the feedback from the pot should be approximately 28 counts and the polang stop plate on the feed should be horizontal and facing to the right (when looking face onto the feed).

If no pol motor drive is present verify the pol reading on the DAC isn’t out of range (i.e. displaying a value of either 0 or 255). If one of these values are displayed its possible the pot isn’t aligned correctly and that adjusting it may bring it back within its range. Back the pot off from the main gear sprocket and rotate its pulley verifying if the feedback changes on the DAC once the pot has been realigned. If so calibrate the pol pot and verify operation as described in the later stages of this document. If the pol count on the DAC doesn’t change when the pot is adjusted the pot has failed and is outputting a default value, no drive will be issued to the pol motor as the value is out of the range which the system operates in.

If the DAC is displaying the correct reading but the LNB isn’t in the correct orientation this could be a calibration issue or an indication that the pot isn’t outputting the correct resistance. Verify the resistance of the pot using a multi-meter as per the following section of this document.

Now drive the feed assembly to its upper end stop, the pol reading should be approximately 210 counts. At this position the polang stop plate on the feed should be horizontal, facing towards the left.

If the DAC is displaying the correct reading but the LNB isn’t in the correct orientation this could be a calibration issue or an indication that the pot isn’t outputting the correct resistance. Verify the resistance of the pot using a multi-meter as per the following section of this document.

If the feed assembly has 180 degrees of rotation but the LNB doesn’t align itself in the correct horizontal/vertical positions then the pot is operational but not calibrated correctly. Refer to the pol alignment and verification section of this document.

Field Service Procedure – Pol Pot Kit, VSAT, XX97, XX97A & XX97B

5. Verify the Resistance of the Pol Pot:

The polang potentiometer (pol pot) consists of an internal slider as well as a CW and CCW contact. To verify the resistance of the pot a multi meter can be used to measure between the slider and one of the wipers whilst rotating the shaft through its range and verifying the 0 – 5 ohms is outputted correctly. Disconnect J1 from motor termination PCB assembly.

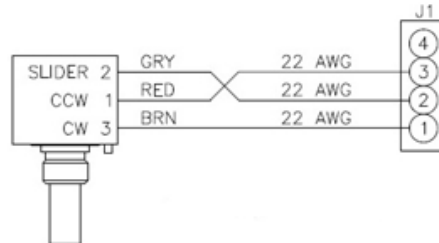

<p>Looking down onto the shaft of the pot rotate it clockwise until it reaches its end stop.</p> <p>Now measure the resistance between the slider and the CCW contact (grey cable, pin 2 on the IDC connector and the red cable pin 3 on the IDC connector).</p> <p>The feedback should be approximately 5k ohms.</p>	
<p>Now slowly rotate the shaft of the pot counter clockwise, the reading should count down sequentially. After one and a half turns the pot will be in the centre of its range giving a resistance of approximately 2.5k ohms.</p>	
<p>Continue to rotate the pot until the counter clockwise end stop (it will now have turned through all 3 rotations of its range) the resistance should be approximately 0k ohms.</p>	

Leaving the pot at its counter clockwise end stop measure between the clockwise contact and the slider (grey cable, pin 2 on the IDC connector and the brown cable pin 1 on the IDC connector) the resistance should be reversed from the previous rotation reading 5 ohms. Rotating the shaft of the pot clockwise should reduce the resistance through its range to 0 ohms.

Any error with the pot not giving the correct resistance is an indication the pot is defective and needs replacing.

Field Service Procedure – Pol Pot Kit, VSAT, XX97, XX97A & XX97B



6. Replacing the Polang Potentiometer Assembly:

6.1. Tools.



- Snips/Cutters
- #1 Phillips Screwdriver
- Loctite 242
- Cable Ties/Tie Wraps

6.2. Procedure.

Procedure for replacing the XX97, XX97A and XX97B VSAT antenna Pol Pot assembly, Sea Tel kit part number: 135391 (pol pot assembly part number: 117547).



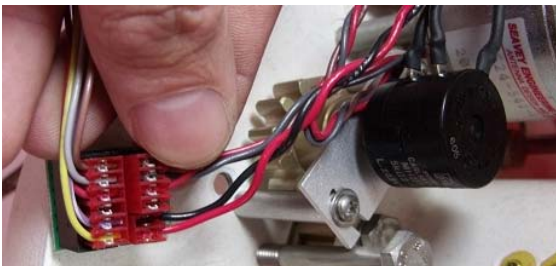

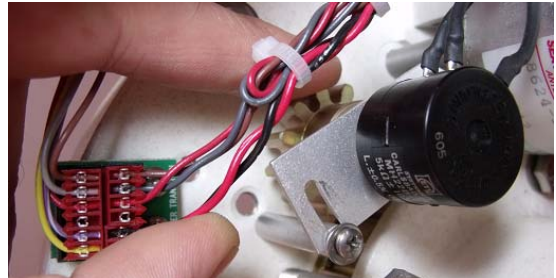
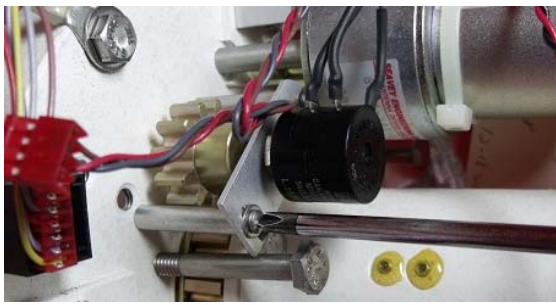
<p>*CAUTION: Power down the pedestal before following this procedure.</p> <p>1. Using a pair of snips remove the cable ties securing the pol pot harness.</p>	
<p>2. Disconnect the Pol Pot's IDC connector from the termination block.</p>	
<p>3. Loosen the screw on the slotted side of the pol pot bracket and undo the screw securing the pol pot assembly to the feed.</p> <p>4. Remove the pol pot assembly.</p>	

Field Service Procedure – Pol Pot Kit, VSAT, XX97, XX97A & XX97B









<p>5. Apply Loctite 242 to each of the pol pot mounting screws and loosely install them securing the replacement pol pot assembly to the feed.</p> <p>6. Do not engage the pulley to the main sprocket at this time.</p>	
<p>7. Connect the polang potentiometer IDC connector to the termination block.</p>	
<p>8. Secure the Pol Pot harness with cable ties.</p>	
<p>9. Using the following procedure calibrate the position of the polang potentiometer.</p> <p>*Note: Damage may occur if the feed is allowed to drive without the pot being engaged. Ensure the Pol Type is set to "0009".</p>	
<p>10. Once the polang potentiometer has been correctly calibrated engage the pulley with the main sprocket and secure the assembly in place.</p>	



7. Pol Pot Alignment and Verification - VSAT:

1. Drive the reflector to zero degrees of elevation to view the orientation of the LNB:

Press the **TRACK** button to turn the tracking function off (if applicable) to prevent the antenna from going into a search. Push the **NEXT** button until the 'Antenna' window is displayed (the screen will show the AZ, EL and REL values). Press the **ENTER** button twice to isolate the 'EL' window and then press the  arrow to activate it (a cursor will be displayed). Now use the  and  arrow keys to scroll the cursor along and use the  and  arrow keys to change the elevation value to "00.0" and press the **ENTER** button.

2. Set the Pol Type to manual mode:

Enter the 'Setup Menu' by pressing and holding the   arrow keys together until the 'EL Trim' or 'Auto Trim' window is displayed. Push the  arrow key until the 'Polang Type' window is displayed. Press the  arrow key to activate the window. Now use the  and  arrow keys to scroll the cursor along and use the  and  arrow keys to change the characters. Set the 'Pol Type' to "000g" which is manual mode and press the **ENTER** button.

3. Press the **ENTER** button to go to the 'Pol Offset' window and verify the default setting is "0030". (If necessary use arrow keys to select appropriate digits and change accordingly).
4. Now keep pressing the **NEXT** button until the 'Antenna' window is displayed (the screen will show the AZ, EL and REL values).
5. Press the **ENTER** button 4 times until 'POL xxx' is displayed and then press the  arrow key to activate the window.
6. Now hold either the  or  arrow key to drive the pol until a count of "120" is displayed.

***Note:** It's advisable to have someone watching the feed while it's being driven as if the pot isn't correctly calibrated there is the possibility to damage the assembly if the polang plate is allowed to drive into the end stop.

Field Service Procedure – Pol Pot Kit, VSAT, XX97, XX97A & XX97B



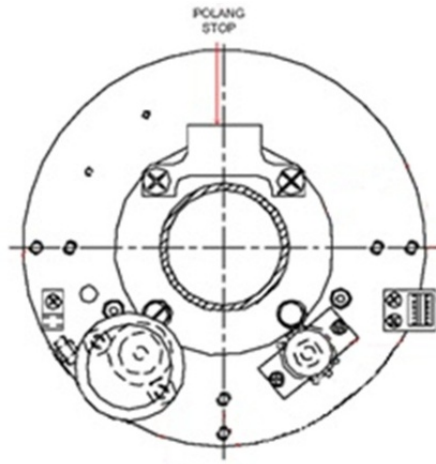

7. Observe the physical alignment of the polang plate:

The polang stop should be facing upwards as shown below. If not continue on to step 8, otherwise skip ahead to step 12.



(Steps 8-12 requires assistance to observe and operate antenna simultaneously)

8. Using the DAC-2202 drive the polang plate to horizontal:

Press the  arrow key to activate the cursor on the pol window. Now hold either the  or  arrow key to drive the polang motor until the polang stop is facing upwards. Now press the  button to de-activate the window.

9. Locate the polang potentiometer on the feed and loosen the screw that secures the slotted mounting plate (fig. 1.1) with a #1 Phillips screwdriver and then carefully move the pol pot gear out of alignment with the main sprocket (fig. 1.2).



(Fig 1.1)



(Fig 1.2)

10. Align the potentiometer:

On the DAC verify the cursor is not displayed on the pol window, if it is press the  button (Fig 1.3) (failure to do this will result in display not changing). Now rotate the pot manually until a count of 120 is achieved (Fig 1.4) once calibrated reinstall the pot on the main sprocket

***Note:** When re-installing the pot onto the main sprocket its common for the reading to change as the teeth of the sprockets are engaged. Because of this the tolerance is +/- 2 degrees so 118-122 counts.

Field Service Procedure – Pol Pot Kit, VSAT, XX97, XX97A & XX97B





(Fig 1.3)











(Fig 1.4)

11. Drive the pol motor to its upper and lower electrical limits and verify the assembly drives in the correct direction and that the feed assembly has 180 degrees of rotation:

On the DAC press the  arrow key to display cursor underneath the pol value and then press and hold the  arrow key to drive the feed to its upper end stop. Verify the assembly drives 90 degrees so the polang stop is horizontal and facing to the left (the pol reading should be approximately 211 counts). Now press and hold the  arrow key to drive the feed to its lower end stop and verify the polang stop is horizontal and facing to the right (the pol count should be approximately 28 counts).





12. Set the Pol Type to Automatic (auto pol):

Press and hold the   arrow keys together until the 'EL Trim' or 'Auto Trim' window is displayed. Push the  arrow key to scroll through the settings until the 'Pol Type' window is displayed and press the  arrow key to activate the window. Now use the  and  arrow keys to scroll the cursor along and use the  and  arrow keys to change the value from "0009" to "0072" and then press the  button to put the system back into automatic polang (auto pol) mode.

Watch the LNB and verify it returns to the correct reception position (while the POL motor is driving the target light will be illuminated on the DAC).

***Note:** If making adjustments to the polarization alignment of a VSAT antenna contacting the NOC to run through a cross-pol isolation test and calibrating the Pol Offset will be necessary.

13. Save the settings in the DAC-2202:

Press and hold the   arrow keys together briefly, "Save New Parameters" will be displayed. Press the  arrow key to activate the window and then press the  button, "Parameters Saved" will be displayed and the pol type and pol offset will be stored in the DAC.